

Radio Remote Controls

Protean™ | L Series | K Series



Contents

Radio Remote Controls	3
Protean™ Series	4-9
Protean™, Basic Receivers and Transmitter	4-7
HT Series Transmitter	8
L8 Series Transmitter	9
L Series	10-15
L10 Series	10-11
L12 Series	12-13
L40 “Belly Box” Series	14-15
K Series	16-22
K Series, General Description	16
K1 & K2 Series	17-18
K1 & K2 Specification Data Sheet	19
K3 & K4 Series	20-21
K3 & K4 Specification Data Sheet	22
Radio Remote Control Accessories	23
Safety and Reliability	24-25
Appendices	26-29
Appendix I - K Series Push Button Functions Settings	26-27
Appendix II - K Series Special Function Settings	28
Appendix III - Terms, Conditions, Warranty	29
Conductix-Wampfler Push Button Pendants	30
Other Products by Conductix-Wampfler	31
Conductix-Wampfler - Contact Information	32

Radio Remote Controls

Conductix-Wampfler has marketed ergonomic, economical, and high quality Radio Remote Controls since the early 1990's.

We offer a number of models to suit the unique needs of demanding industrial users. These units are competitively priced and shipped from stock for quick delivery.

The experienced engineering and sales people at Conductix-Wampfler are experts in the application of Radio Remote Controls to all kinds of industrial applications

As an alternative to radio remote controls, Conductix-Wampfler also offers "hard-wired" Push Button Pendants - See Pg. 30 and catalog CAT1001.

All Conductix-Wampfler plants in the United States, Germany, France, and Italy are ISO 9001:2000 certified. Our stringent quality systems assure that you will get the right product every time. See Pg. 31 for a sampling of our other quality products.

Conductix-Wampfler in the USA, headquartered in Omaha, NE, started as "Industrial Electric Reels" (IER) and later merged with "Insul-8 Corporation", after relocating the Insul-8 plant to Harlan, IA. In 2006, the company, part of the Delachaux Group since 1975, was renamed "Conductix".

In 2007, with the merger of Conductix and Wampfler, the company is now the world leader in the design and manufacture of high performance energy and data transmission products for industrial applications.



Protean™ Series

Economical Protean™ Radio Remote Control transmitters are available in 4, 6, & 8 button single-speed configurations. 330 foot (100 meter) range. FCC 310-320 Mhz AC and DC models.

Protean™ "HT" and L8 Transmitters

2-motion, 2-speed HT and 3-motion 1-speed L8 models have positive detent positions, e-stop switch, and removable key. 330 foot (100 meter) range. FCC 310-320 Mhz AC and DC models.

L10 and L12 Series

The L10 Series is a 2-speed transmitter with 8 buttons for control of 3-4 motions. The L12 is also 2-speed, but has 12 buttons for control of up to 5 motions. FCC 310-320 Mhz AC models only.

L40 Series

A "belly box" style unit with 5-speeds, dual joystick. Up to 8 motions using A/B switches. FCC 310-320 Mhz AC models only.

K1 and K2 Series

The rugged K1/K2 radios have eight 1-speed or 2-speed buttons for control over 3-4 motions. 330 foot (100 meter) range; FCC 433-435 MHz. AC or DC models.

K3 and K4 Series

The K3/K4 has twelve 1-speed or 2-speed transmitter buttons for control over up to 5 motions. FCC 433-435 MHz. AC or DC models.

Protean™ Radio Remote Control

Protean Transmitters



Economical Protean™ Radio Remote Controls provide safe and reliable operation of many types of electrical machinery and crane controls. These FM radios have internal antennas for a 330 foot (100 meter) range and many advanced security and reliability features. Kits include one receiver and either one or two transmitters, as noted below. NEMA 4 (IP65) enclosures.

Transmitter specifications

- Runs on 2 standard “AA” alkaline batteries; low power consumption ensures long battery life. Includes low power indicator
- All single-speed buttons
- Jammed button detection
- Shock resistant case
- Weighs only 0.34 lbs. (155g) with batteries
- FCC Part 15 - no license required



Please Note:

All transmitters will require the Serial Number for proper matching to receiver for programming.

Protean Series radios will also need Channel Number 0-45 specified at time of order.

Receiver specifications

- Multiple supply voltages:
DC: 12 ~ 24 Volts DC (or 24 Volts AC)
AC: 48/110, 110/220, plus or minus 10%, 50/60 Hz. Default is 48/110 w/110 selected
- Independent common configuration for mixed control voltage applications
- Power-on/mainline contact
- LED display of power and contact closure status
- Sensitivity: Approximately -105 dBm
- Prewired cable, 6 feet long (1.83 m)
- Control relay rating: 10A @ 125 VAC; 5A@ 250 VAC; 8A @ 30 VDC
- 4-point shock mount designed for demanding mobile and industrial applications

Four Button Radio Kit

Operation Description	Voltage Type	No. of Transmitters	Part No.	Wt lb (kg)
Normally-open, single-speed buttons, with a stop, start/auxiliary, up and down buttons. The radio is suitable for a single motion (2 directions) and also provides a power-on (mainline) connection. The start button also doubles as an additional auxiliary relay.	AC	1	700PR04	2.74 (1.24)
	AC	2	700PR04D	3.08 (1.40)
	DC	1	700PR04-DC	2.74 (1.24)
	DC	2	700PR04D-DC	3.08 (1.40)

Six Button Radio Kit

Operation Description	Voltage Type	No. of Transmitters	Part No.	Wt lb (kg)
Normally-open, single-speed buttons, with a stop, start/auxiliary, up and down buttons. The radio is suitable for two motions (4 directions) and provides a power-on (mainline) connection. The start button also doubles as an additional auxiliary relay.	AC	1	700PR06	2.74 (1.24)
	AC	2	700PR06D	3.08 (1.40)
	DC	1	700PR06-DC	2.74 (1.24)
	DC	2	700PR06d-DC	3.08 (1.40)

Protean™ Radio Remote Control

Eight Button Radio Kit

Operation Description	Voltage Type	No. of Transmitters	Part No.	Wt lb (kg)
Normally-open, single-speed buttons, with a stop, start/auxiliary, up and down buttons. The radio is suitable for three motions (6 directions) and provides a power-on (mainline) connection. The start button also doubles as an additional auxiliary relay.	AC	1	700PR08	2.74 (1.24)
	AC	2	700PR08D	3.08 (1.40)
	DC	1	700PR08-DC	2.74 (1.24)
	DC	2	700PR08D-DC	3.08 (1.40)

Numbered Transmitter Face Plates



Each face plate shown is pre-numbered for 4, 6 or 8 button transmitters.

Description	Part No.
4-Button Face Plate	701P0045
6-Button Face Plate	701P0065
8-Button Face Plate	701P0085

Button Face Plates with Legend



The kits shown below contain either a 4, 6 or 8 button face plate with “blank” spots for legend names and one legend sheet as shown to the below.

To set up the face plate, choose the appropriate label from the legend sheet and apply it to the underside of the faceplate before applying the faceplate to the transmitter. The faceplate is clear in the open button positions allowing the label to show through.

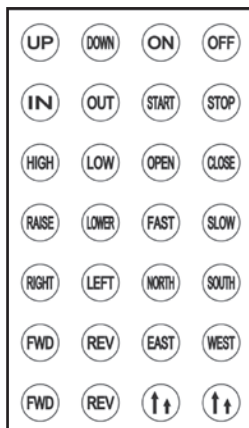

Description	Part No.
4-Button Face Plate, with 2 blank spots	701P0219
6-Button Face Plate, with 4 blank spots	701P0220
8-Button Face Plate, with 6 blank spots	701P0221

Protean™ Dimensions

Protean™ Receiver

Weight: 2.4 lb (1.1 kg) - *Less Cable*

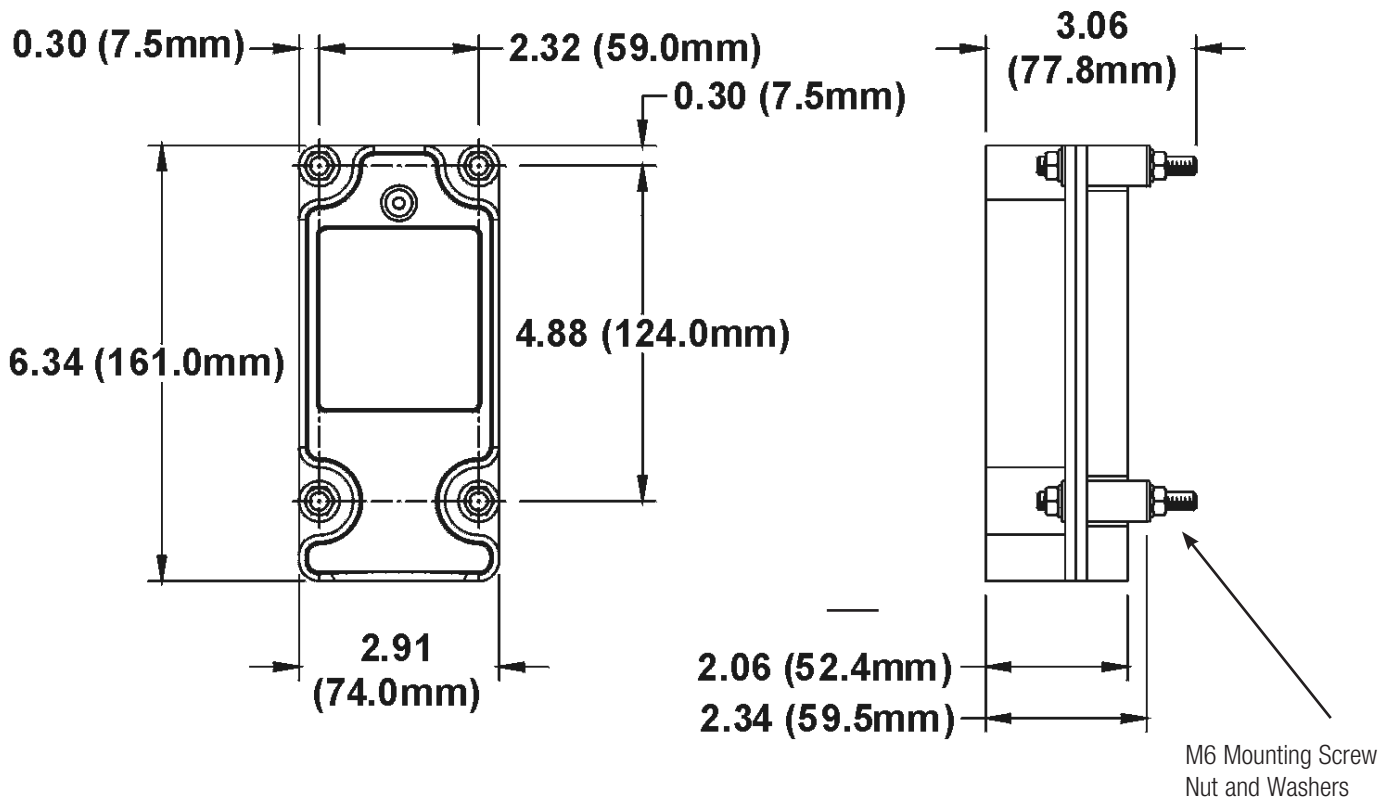

Protean™ Transmitter

Weight: 0.34 lb (0.2 kg) *Including Batteries*

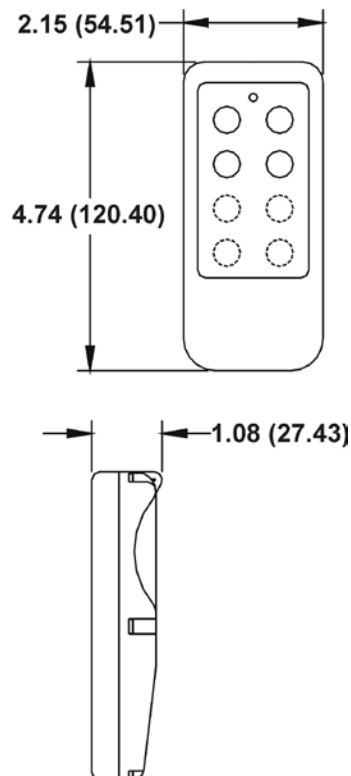

Protean™ Wiring Diagrams

AC type wiring is shown below. Wiring for DC units is the same but Power1 and Power2 are connected to 12-24 VDC. FCC ID#: NCTSAGA1-L8

4-Button Wiring Schematic (AC Type)

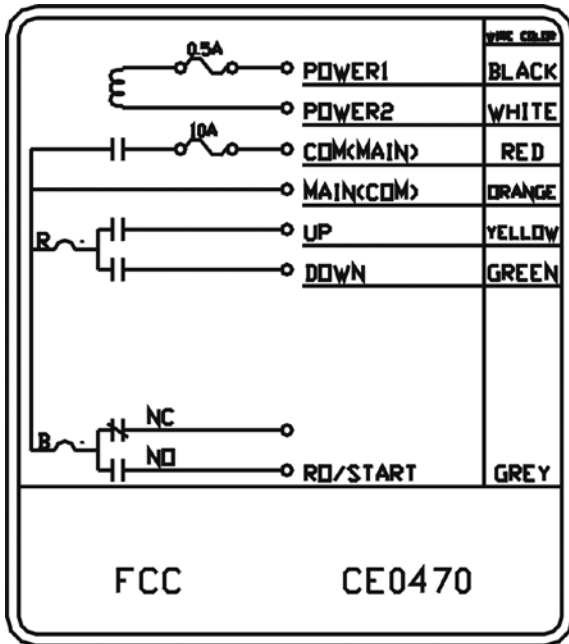

6-Button Wiring Schematic (AC Type)

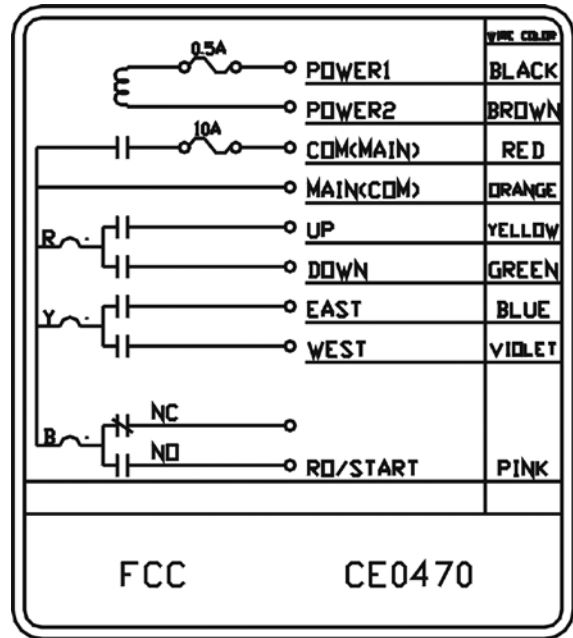

8-Button Wiring Schematic (AC Type)

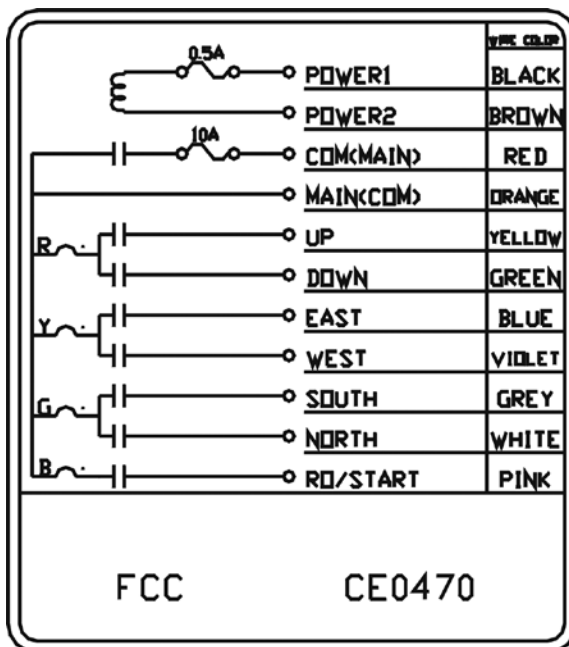

Protean™ HT Radio Remote Control

Protean™ HT Transmitter



P.N. 701PROL6B-TX

The Protean™ HT Radio Remote Control is ideal for controlling hoist and trolley operation. It features two-speed push buttons with distinct position detents. There is a large mushroom E-stop switch with removable water-proof key. The radio functions in a range up to 330 feet and is available for either AC or DC operation.

Transmitter Specifications

- Dimensions: 6.5H x 2.0W x 2.25D (165mm x 51mm x 57mm)
- 4 Buttons: Up, Down, East, West
- Uses 2 AA alkaline batteries
- Shock-resistant design

Protean™ Receiver



Please Note:

All transmitters will require the Serial Number for proper matching to receiver for programming.

Protean Series radios will also need Channel Number 0-45 specified at time of order.

Receiver Specifications

- Dimensions: 6.5H x 3.0W x 2.4D (165mm x 76mm x 60mm)
- NEMA 4 rated (IP65), shock resistant enclosure
- Pre wired with six feet (1.83M) of cable
- Shock-resistant mounting; four bolts with stock absorbers
- Power Options: DC Type: 12 ~ 24 Volts DC (or 24 Volts AC)
AC Type: 48/110, 110/220, plus or minus 10%, 50/60 Hz. Default is 48/110 VAC, 110 VAC selected
- Relay Ratings: 10A @ 125 VAC
5A @ 250 VAC
8A @ 30 VDC

Protean™ HT Radio Kit

Input Power	No. of Transmitters	Part No.
AC	1	700PRO6HT
AC	2	700PRO6DHT
DC	1	700PRO6HT-DC
DC	2	700PRO6DHT-DC

Protean™ L8 Radio Remote Control

Protean™ L8 Transmitter



P.N. 701L8001

The L8 Series Radio Remote Control is ideal for applications that require three motions, such as a hoist, trolley, and bridge motions for an overhead crane, but only requires single speed operation. The L8 is ruggedly built and features a large mushroom E-stop switch and removable water-proof key. The radio functions within a range up to 330 feet and is available for either AC or DC operation.

Transmitter Specifications

- Dimensions: 6.5H x 2.0W x 2.25D (165mm x 51mm x 57mm)
- 6 single-speed buttons: Up/Down, East/West, North/South
- Uses 2 AA alkaline batteries
- Shock-resistant design

Protean™ Receiver

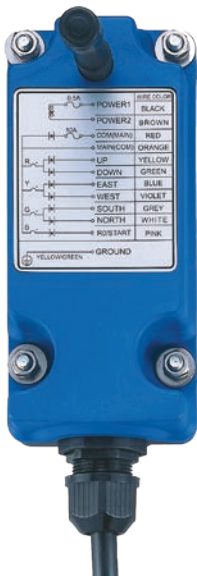

Please Note:

All transmitters will require the Serial Number for proper matching to receiver for programming.

Protean Series radios will also need Channel Number 0-45 specified at time of order.

Receiver Specifications

- Dimensions: 6.5H x 3W x 2.4D (165mm x 76mm x 60mm)
- NEMA 4 rated (IP65), Shock resistant enclosure
- Pre wired with six feet (1.83m) of cable
- Shock-resistant mounting; four bolts with shock absorbers
- Power Options: DC Type: 12 ~ 24 Volts DC (or 24 Volts AC)
AC Type: 48/110, 110/220, plus or minus 10%, 50/60 Hz. Default 48/110V, with 110 V selected
- Relay Ratings: 10A @ 125 VAC
5A @ 250 VAC
8A @ 30 VDC

Protean™ L8 Radio Kit

Input Power	No. of Transmitters	Part No.
AC	1	700PROL8B
AC	2	700PROL8BD
DC	1	700PROL8B-DC
DC	2	700PROL8BD-DC

L10 Series Radio Remote Control

L10 Transmitter

The L10 Series is a 2-speed transmitter with eight buttons for control of 3-4 motions. FCC 310-320 Mhz AC models only. Each kit includes receiver, one or two transmitters, four batteries, strap, legend sheet for each transmitter, spare key, spare fuse kit, and instruction manual. This radio has programmable operation; contact Conductix-Wampfler for details.



P.N. 701L10002

Transmitter Specifications

- Very light weight 0.62 lb. (155g) with batteries
- Runs on two standard alkaline batteries
- Very low power consumption ensures long battery life
- Includes low power indicator
- Modulation: FM
- Internal antenna
- Jammed button detection
- Shock resistant

L10 Receiver



Receiver Specifications

- Multiple supply voltages:
AC Type: 48/110/220 plus or minus 10%, 50/60 Hz.
(Default 110 Selected)
- Independent common configuration for mixed control voltage applications
- Power-on/mainline contact
- Internal LED display of power and contact closure status
- Sensitivity: Approximately -105 dBm
- Pre-wired cable, 9 feet long (2.74m)
- Control relay rating:
10A @ 125 VAC; 5A @ 250 VAC; 8A @ 30 VAC
- Single shock mount designed for demanding mobile and industrial applications
- NEMA 4 (IP65)

L10 Radio Kit

The L10 Series Kit includes four (4) batteries, spare key, spare fuse kit, instruction manual, and a legend sheet for each transmitter. AC only.

Please Note:

All transmitters will require the Serial Number for proper matching to receiver for programming.

L Series radios will also need Channel Number 0-45 specified at time of order.

Operation Description	No. of Transmitters	Part No.
Eight 2-speed buttons, E-stop, key switch, and On/Off Up to 4 motion two speed control with 0 to 2 programmable auxiliary outputs, alarm output, mainline output, and light output.	2	700DL10

L10 Series Dimensions and Wiring Diagram

L10 Dimensions

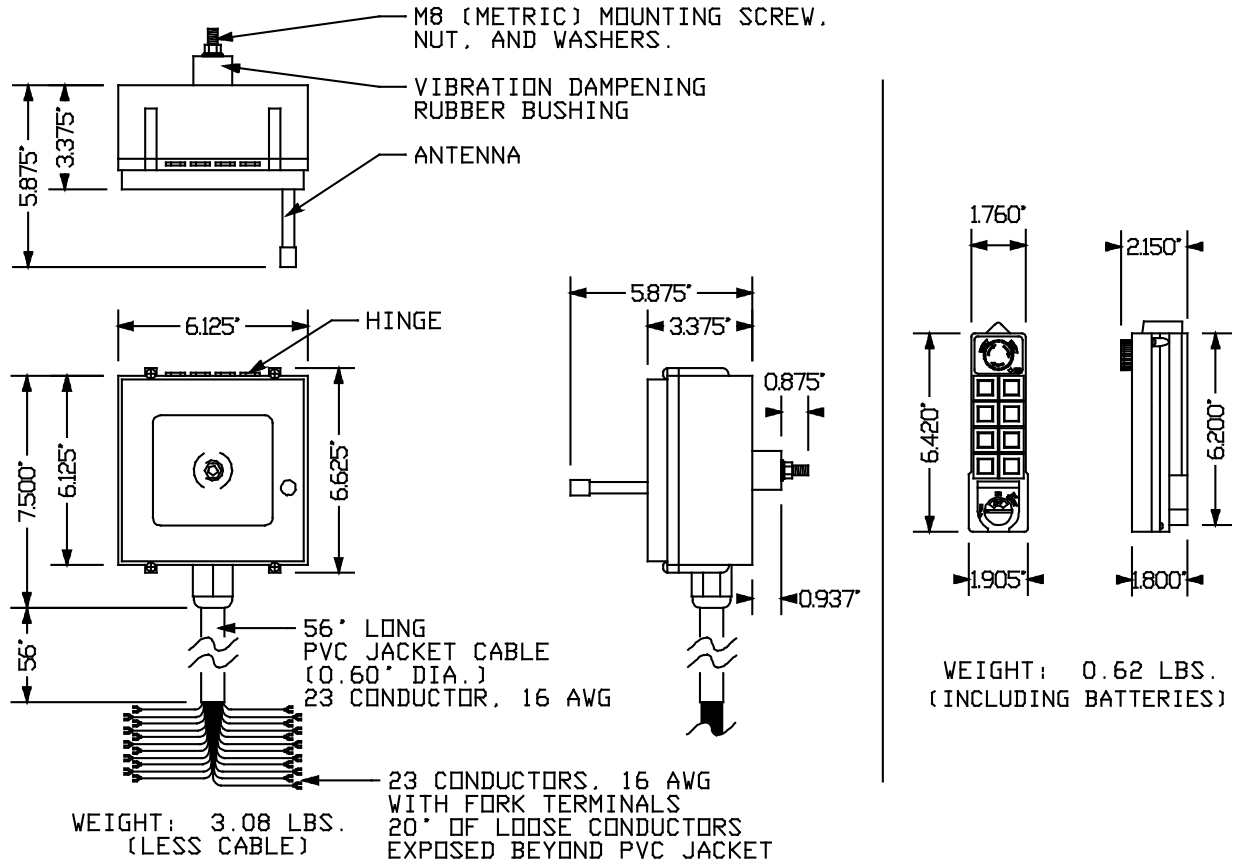

Wiring Diagram

Default wiring diagram shown. Custom programming might alter relay outputs.

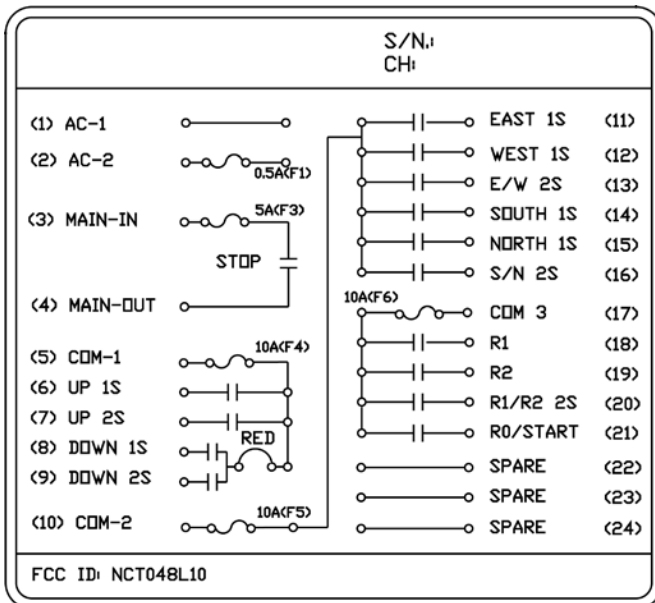

L12 Series Radio Remote Control

L12 Transmitter

The L12 Series is a 2-speed transmitter with twelve buttons for control of up to 5 motions. FCC 310-320 Mhz AC models only. Each kit includes receiver, one or two transmitters, four batteries, strap, legend sheet for each transmitter, spare key, spare fuse kit, and instruction manual. This radio has programmable operation; contact Conductix-Wampfler to discuss your application needs.



P.N. 701L12002

Transmitter specifications

- Very light weight; 1.2 lb (0.55 kg) with batteries
- Runs on 2 standard alkaline batteries
- Very low power consumption ensures long battery life
- Includes low power indicator
- Modulation: FM
- Jammed button detection
- Shock resistant

L12 Receiver



Receiver specifications

- Multiple supply voltages:
AC Type: 48/110/220, plus or minus 10%, 50/60 Hz.
(Default 110 Selected)
- Independent common configuration for mixed control voltage applications
- Power-on/mainline contact
- Internal LED display of power and contact closure status
- Sensitivity: Approximately -105 dBm
- Pre-wired with 6 feet (1.83m) of cable
- Control relay rating:
10A @125 VAC; 5A @ 250 VAC; 8A @ 30 VAC
- 4-point shock mount designed for demanding mobile and industrial applications
- NEMA 4 (IP65)

Please Note:

All transmitters will require the Serial Number for proper matching to receiver for programming.

L Series radios will also need Channel Number 0-45 specified at time of order.

L12 Radio Kit

The L12 Series Kit includes six (6) batteries, spare key, spare fuse kit, instruction manual, and a legend sheet for each transmitter. AC only.

Operation Description	No. of Transmitters	Part No.
Twelve 2-Speed buttons, with E-Stop, Key Switch, and On/Off. Up to 5 motion two speed control with 2 to 7 programmable auxiliary outputs, alarm output, mainline output, and light output.	2	700DL12

L12 Series Dimensions and Wiring Diagram

Dimensions

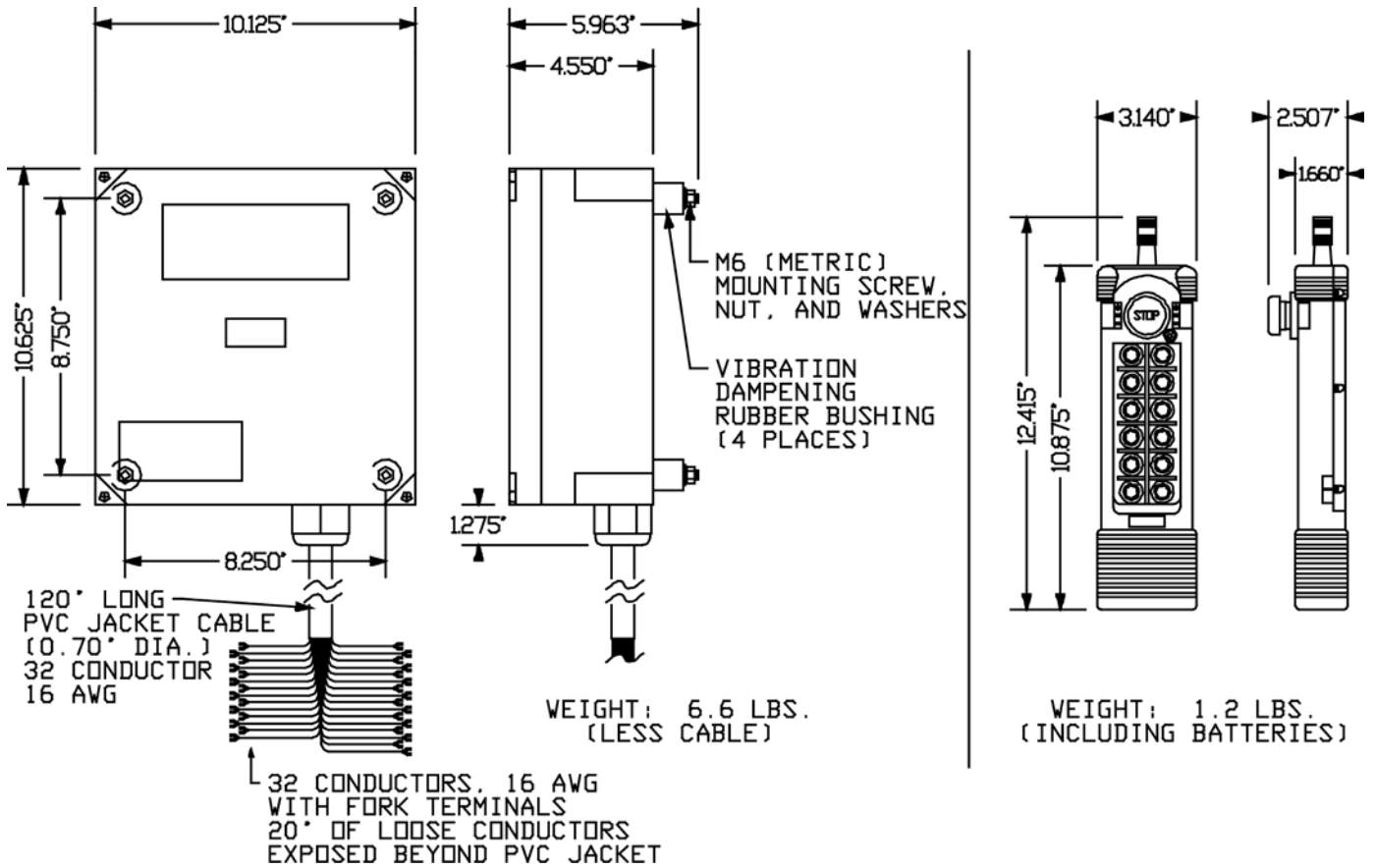

Wiring Diagram

Note: Default wiring diagram shown. Custom programming might alter relay outputs.

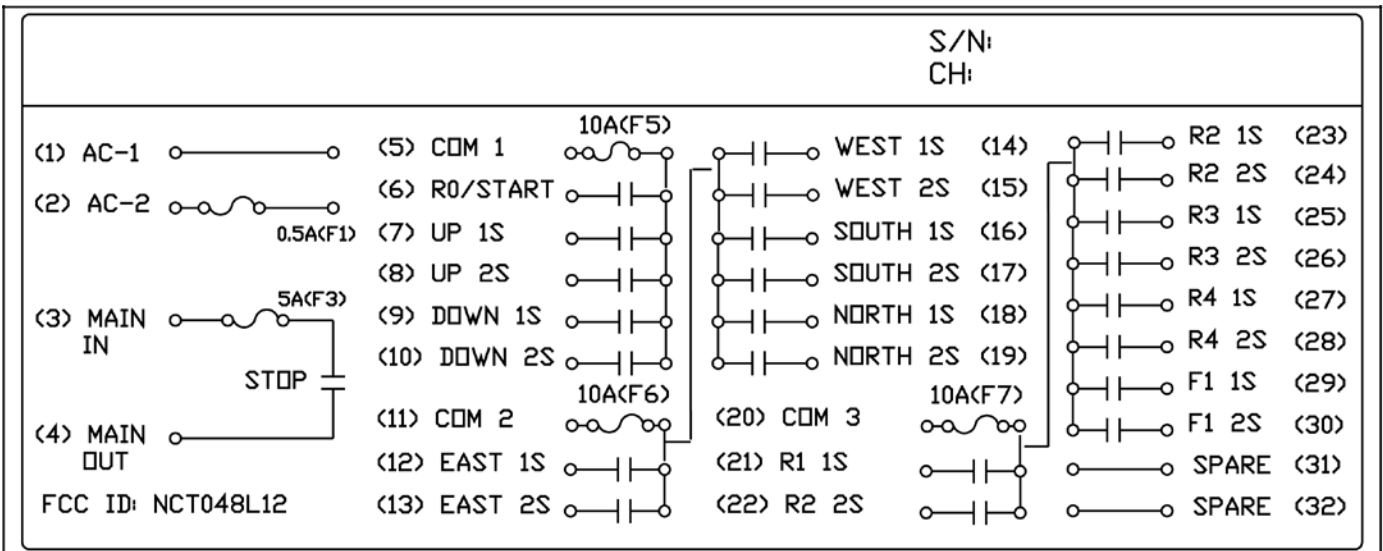

L40 Series Radio Remote Control

L40 Transmitter

The L40 Series is a “belly box” style transmitter unit with 5-speeds, dual joystick. Up to eight motions using A/B switches. FCC 310-320 Mhz AC models only.



P.N. 701L40101

Transmitter specifications

- Very light weight; 1.9 lb (0.86 kg) with batteries
- Runs on 4 standard alkaline batteries
- Very low power consumption ensures long battery life
- Includes low power indicator
- Modulation: FM
- Internal Antenna
- Jammed joystick detection
- Shock resistant
- 2 Selector Switches (A-Both-B or A-Off-B)
- Optional toggle switches (replace selector switches)
- 2 Dual Axis Joysticks (can be Gated)

L40 Receiver



Receiver specifications

- Multiple supply voltages:
AC Type: 48/110, 110/220, plus or minus 10%, 50/60 Hz.
(Default 48/110, 110 selected)
- Independent common configuration for mixed control voltage applications
- Power-on/mainline contact
- LED display of power and contact closure status
- Sensitivity: Approximately -105 dBm
- Two pre-wired cables, each 6 feet long (1.83 m) cable
- Control relay rating:
10A @125 VAC; 5A @ 250 VAC; 8A @ 30 VAC
- 4-point shock mount designed for demanding mobile and industrial applications
- 40 dynamically assigned relays
- NEMA 4 (IP65)

Please Note:

All transmitters will require the Serial Number for proper matching to receiver for programming.

L Series radios will also need Channel Number 0-45 specified at time of order.

L40 Radio Kit

The L40 Series Kit includes four (4) batteries, spare key, spare fuse kit, instruction manual, and a legend sheet for each transmitter. AC only.

Operation Description	No. of Transmitters	Part No.
Dual joystick, 5 speed controls with E-stop, key switch, 2 selectors, and two push buttons. Up to 8 motions through the use of A-B-Both switches. 2 programmable auxiliary outputs, mainline output, and light output.	2	700DL40

L40 Series Dimensions and Wiring Diagram

Dimensions

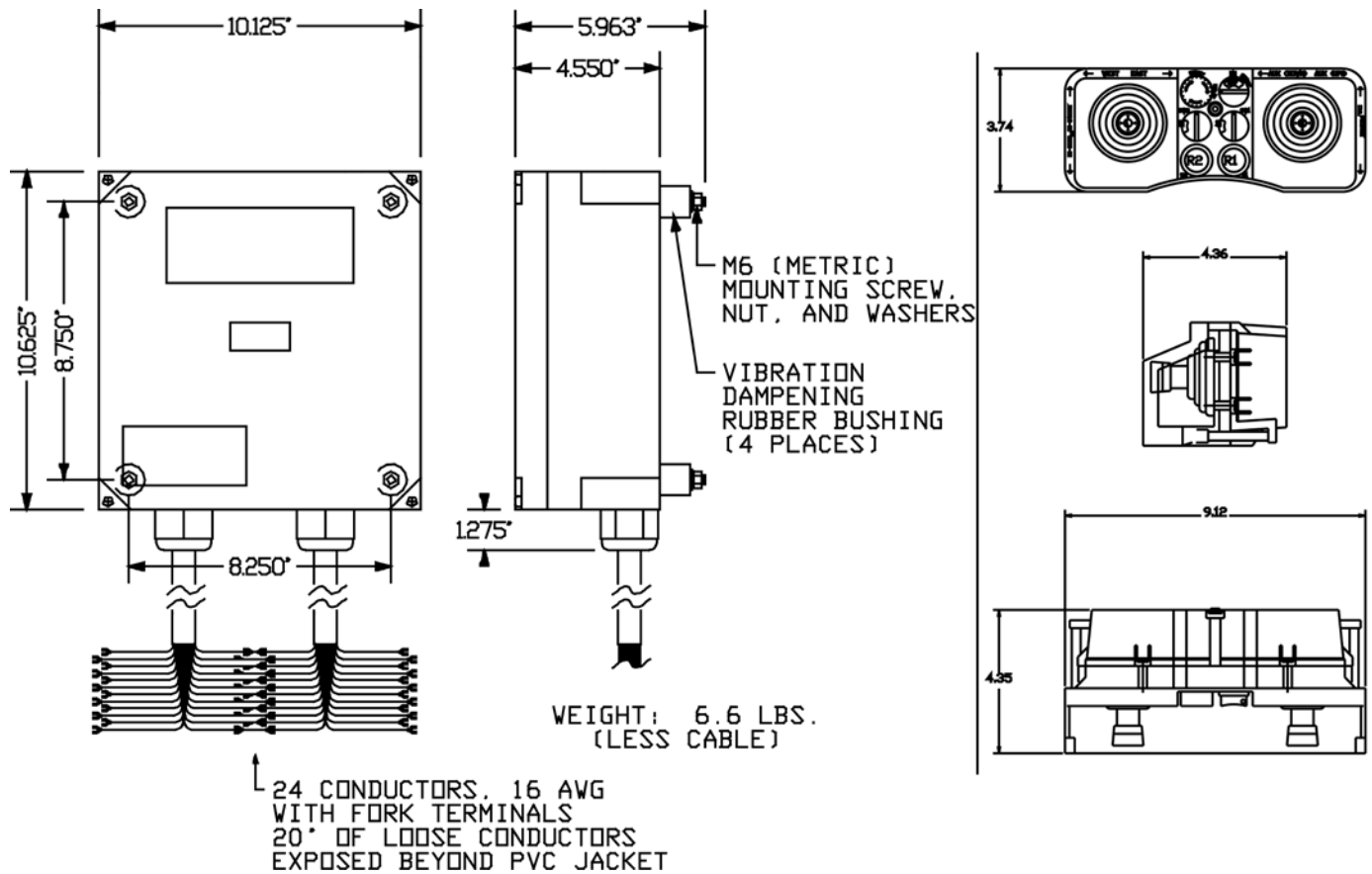

Wiring Diagram

Note: Default wiring diagram shown. Custom programming will alter relay outputs.

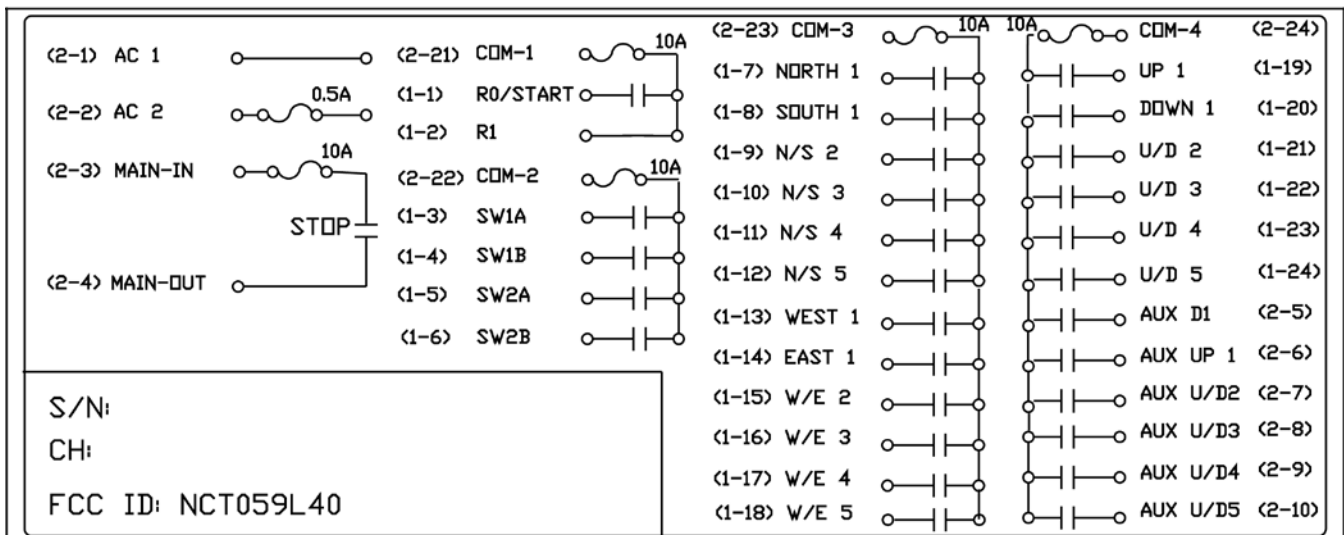

K Series Radio Remote Controls



K-Series Radio Remote controls are a state-of-the-art radio control system. Check the many great features below and on Pgs. 17 through 22.

Specifications

- Operating Range: 330 feet (100m) - Up to ~1000 feet (300m) - depending on environment
- Frequency: 433.05 to 434.775 MHz, depending on operating channel
- Available Channels: 70
- Enclosure: Nylon with glass fiber, NEMA4 (IP65)
- Emission Power: Less than 10 mW, eight level adjustments
- Channel Spacing: 25 kHz
- FCC Part 15; no license required
- Emission Designator: 114KF1D

Safety Features

- Emergency Mushroom Switch (EMS or “E-Stop”) is Independently Certified EN-ISO 13849-1 Category 4.
- Dual Independent Micro-controllers
- Dual Mainline Relays Connected in Series (Each Independently Controlled)
- Current sensing jammed relay detection circuit.
- Double contact on EMS in Transmitter



Advanced Features

Remote Pairing

The transmitter can contact a receiver and “download” the system data via radio, allowing you to replace a lost or damaged radio without any additional tools.

Pitch and Catch Operation

Can be enabled allowing a single receiver to be safely operated by two different operators.

Auto-scanning

The Radio is factory programmed to choose between two channels depending upon which one is the clearest on every start, alternately the radio can scan all channels on site and find the clearest pair of channels to use.

Adjustable emissions power

Allows some range control of the radio and will reduce the possibility of unnecessary interference by adjacent radios.

Flexible Configuration

The radio can be factory configured to handle a variety of functions, such as:

- On/Off, Maintained or Momentary Buttons with or without interlocking
- Anti-Plugging and Multiple Speed Time Delays
- Magnet Operation Mode (one button to engage, two button to release)
- Additive and Make-before-Break (2-speed control)
- Independent Receiver and Transmitter Time outs (Power Off)

See Appendices I and II, Pgs. 26 to 28 for more information.

Please Consult the Factory for Even More Options!

K1 and K2 Series Radio Remote Controls

K1 and K2 Transmitter



K1 P.N. 52528
K2 P.N. 52529

Transmitter Features

- Antenna: Integrated/Internal
- 3 stage low power indicator
- Removable Key [For push button start, consult factory.]
- Power consumption: Less than 28mA
- Powered by four standard or rechargeable AA batteries

Please Note:

All transmitters will require the Serial Number for proper matching to receiver for programming.

*Default setting on Start/Alarm button is for the built-in alarm. Changing this setting or if Aux 1 is needed will disable the alarm output.

K Series radios will require Serial Number to be matched for easy out-of-the-box operation.

K1 and K2 Receiver



Receiver Features

- Integrated Horn/Alarm built into receiver
- Visible external power indicator
- Receiver has 2 meter (6 ft) pre-wired cable.
- Receiver features F-Style Antenna connector for easy antenna extension.
- Supply Voltages: DC: 12-24; AC: 24, 48, 110, and 220. 110V is the default. Please contact the Factory for part numbers for different supply voltages.

K1 Series Radio Kit - 110V*

The K1 Series Kit includes four (4) batteries, spare key, spare fuse kit, instruction manual, and a legend sheet for each transmitter. AC only.

Operation Description	No. of Transmitters	Part No.
Single speed, eight button transmitter with E-stop, key switch, and On/Off. Up to 4 motion single speed control with 0 to 2 programmable auxiliary outputs, alarm output, mainline output, and light output.	1	700SK1
	2	700DK1

K2 Series Radio Kit - 110V*

The K2 Series Kit includes four (4) batteries, spare key, spare fuse kit, instruction manual, and a legend sheet for each transmitter. AC only.

Operation Description	No. of Transmitters	Part No.
Dual speed, eight button transmitter with E-stop, key switch, and On/Off. Up to 4 motion two speed control with 0 to 2 programmable auxiliary outputs, alarm output, mainline output and light output.	1	700SK2
	2	700DK2

* Default Supply Voltage is 110V AC. Please contact factory for part numbers for different supply voltages: -DC, -48V, -220V

K1 and K2 Series Dimensions and Wiring Diagram

Dimensions

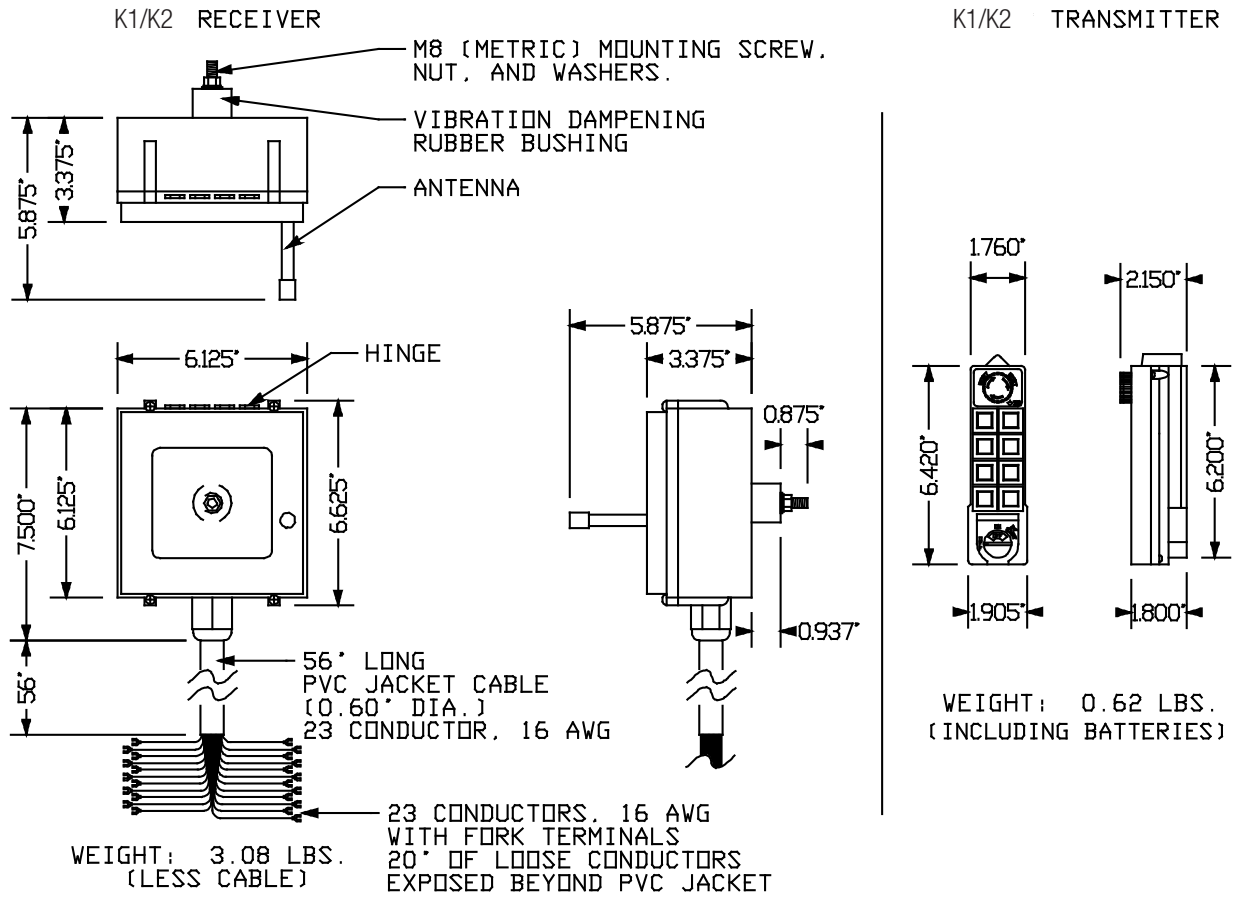

Wiring Diagrams

Shown below are the "default" wiring diagrams. If custom programming has been done, this might alter the relay outputs. See Manual for DC wiring diagrams.

K1 Series

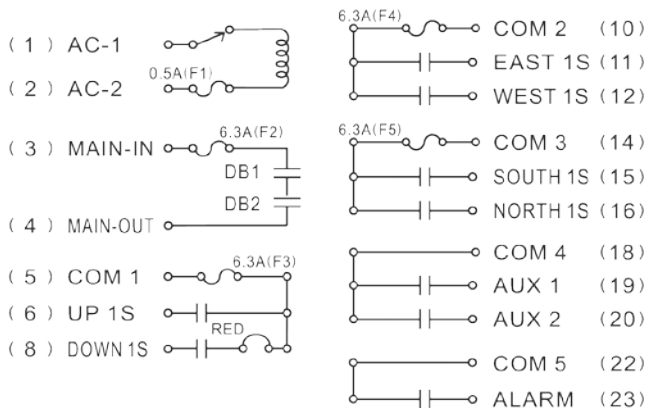

K2 Series

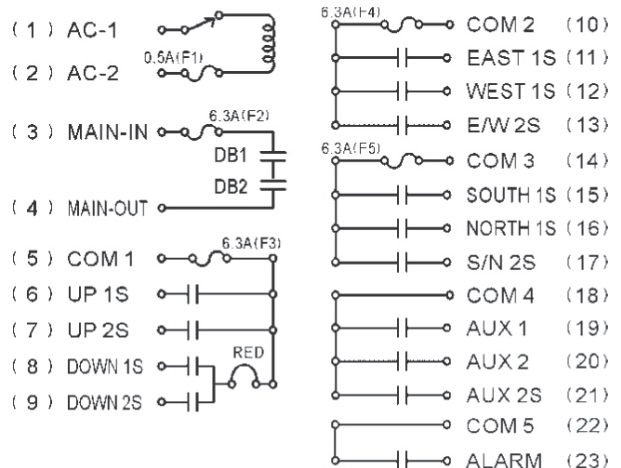

K1 and K2 Series Specification Data Sheet

Request Date	_____	Sales Person	_____
Company	_____	Name	_____
	_____	Title	_____
	_____	Phone	_____
	_____	Fax	_____
Company Type	_____	E-mail	_____

Model Needed K1 (Single Speed) K2 (Dual Speed)

Write the desired button function on the lines next to the buttons:

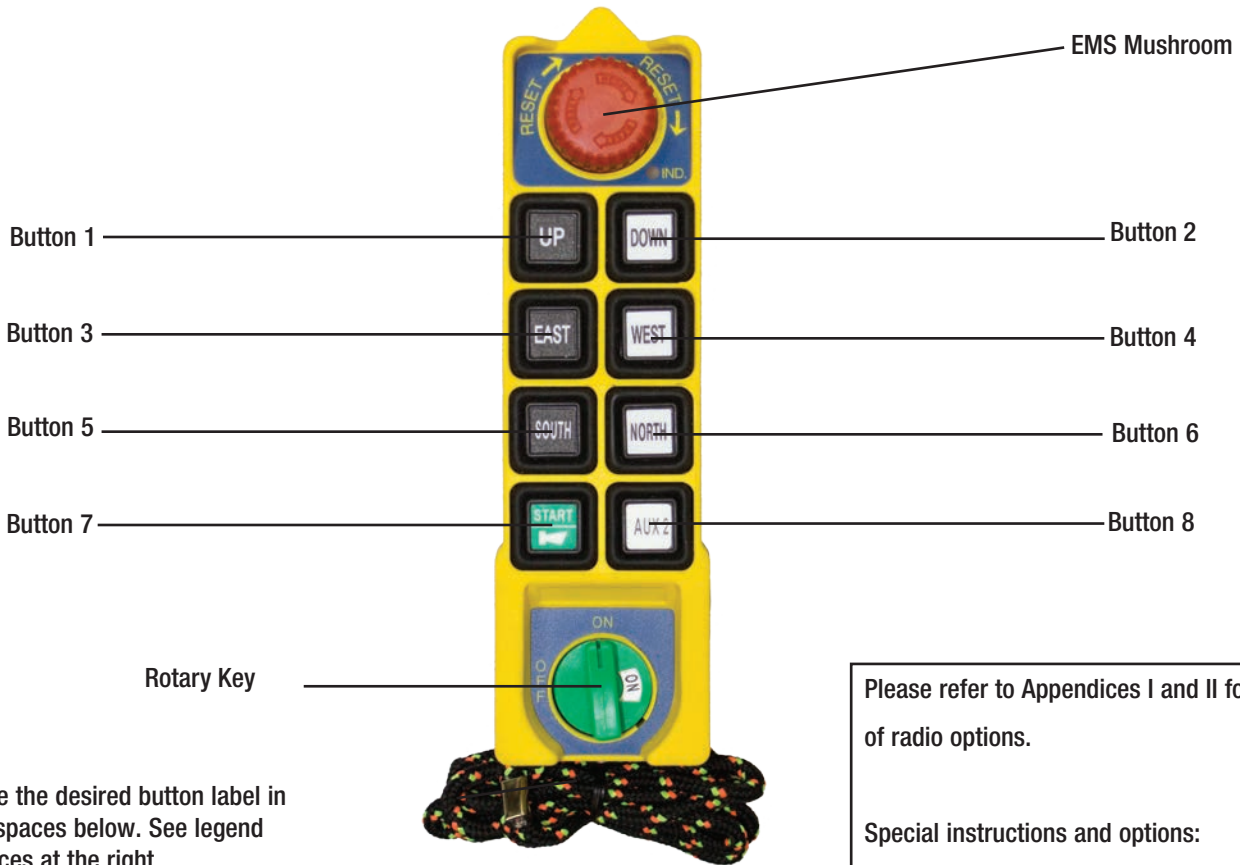

Write the desired button label in the spaces below. See legend choices at the right.

Button 1 _____

Button 2 _____

Button 3 _____

Button 4 _____

Button 5 _____

Button 6 _____

Button 7 _____

Button 8 _____



Part No. 52517

Please refer to Appendices I and II for details of radio options.

Special instructions and options:

K3 and K4 Series Radio Remote Control

K3 or K4 Transmitter



K3 P.N. 52530

K4 P.N. 52531

Transmitter Features

- Antenna: Integrated/Internal
- 3 stage low power indicator
- Removable Key
(For push button start, consult factory)
- Power consumption: Less than 28mA
- Powered by 4 Standard or Rechargeable AA batteries

Please Note:

All transmitters will require the Serial Number for proper matching to receiver for programming.

*Default setting on Start/Alarm button is for the built-in alarm. Changing this setting or if Aux 1 is needed will disable the alarm output.

K Series radios will require Serial Number to be matched for easy out-of-the-box operation.

K3 or K4 Receiver

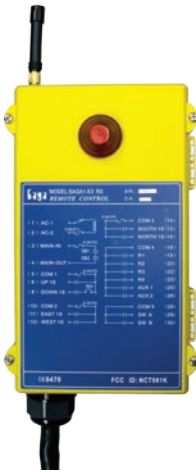

Receiver Features

- Integrated Horn/Alarm built into receiver
- Visible external power indicator
- Receiver has 2 meter (6ft) pre-wired cable.
- Receiver features F-Style antenna connector for easy antenna extension.
- Supply Voltages: DC 12-24, AC: 24, 48, 110, and 220. 110 VAC is the default.

K3 Series Radio Kit - 110VAC*

The K3 Series Kit includes six (6) batteries, spare key, spare fuse kit, instruction manual, and a legend sheet for each transmitter. AC only.

Description	No. of Transmitters	Part No.
Single speed, 12 Button transmitter with E-stop, key switch and On/Off. Up to 5 motion single speed control with 2 to 7 programmable auxiliary outputs, alarm output, A/B outputs, mainline output, and light output.	1	700SK3
	2	700DK3

K4 Series Radio Kit - 110VAC*

The K4 Series Kit includes six (6) batteries, spare key, spare fuse kit, instruction manual, and a legend sheet for each transmitter. AC only.

Description	No. of Transmitters	Part No.
Dual speed, 12 Button transmitter with E-stop, key switch and On/Off. Up to 5 motion two speed control with 2 to 7 programmable auxiliary outputs, alarm output, A/B outputs, mainline output and light output.	1	700SK4
	2	700DK4

* Default Supply Voltage is 110V AC. Please contact factory for part numbers for different supply voltages: -DC, -48V, -220V

K3 and K4 Series Dimensions and Wiring Diagram

Dimensions

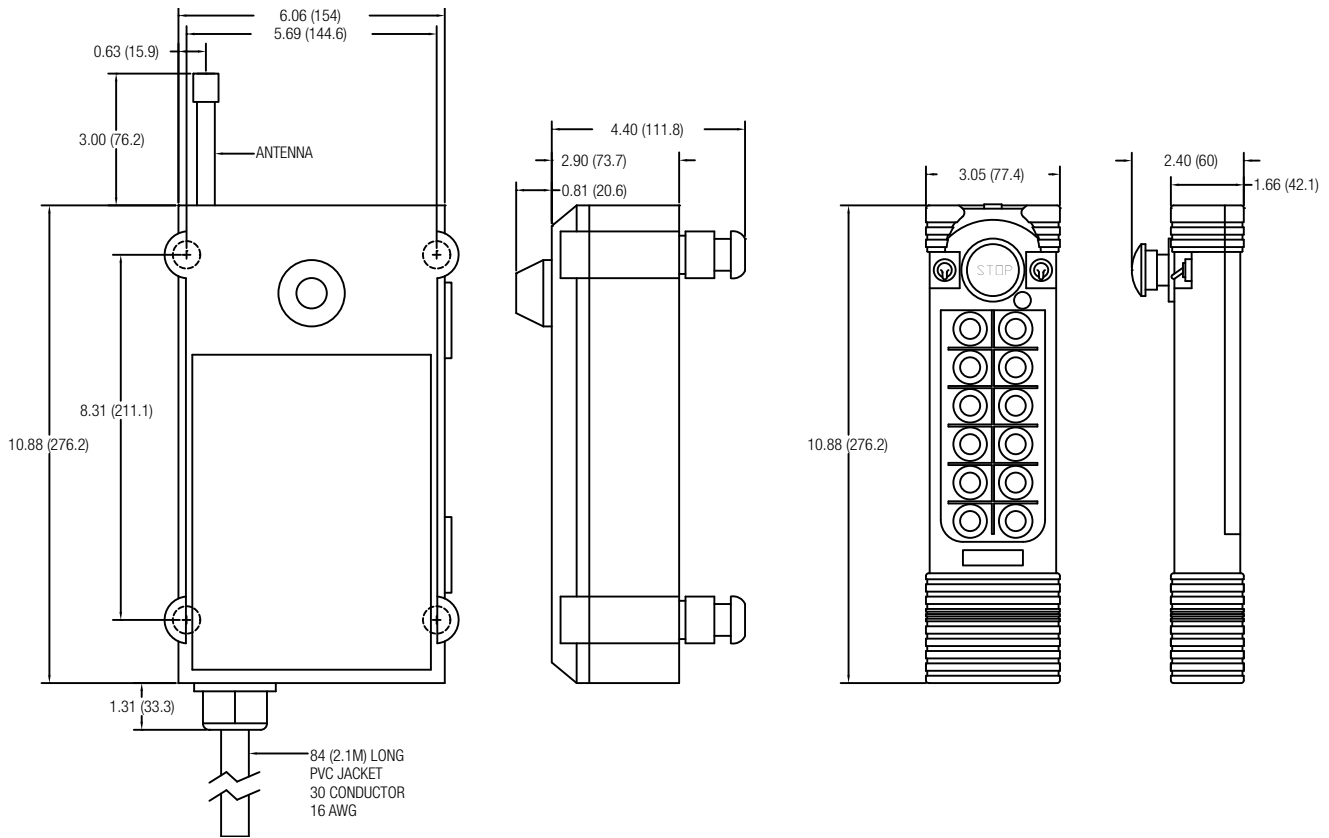

Wiring Diagrams

Shown below are the default wiring diagrams. Custom programming might alter the relay outputs. See Manual for DC wiring diagrams.

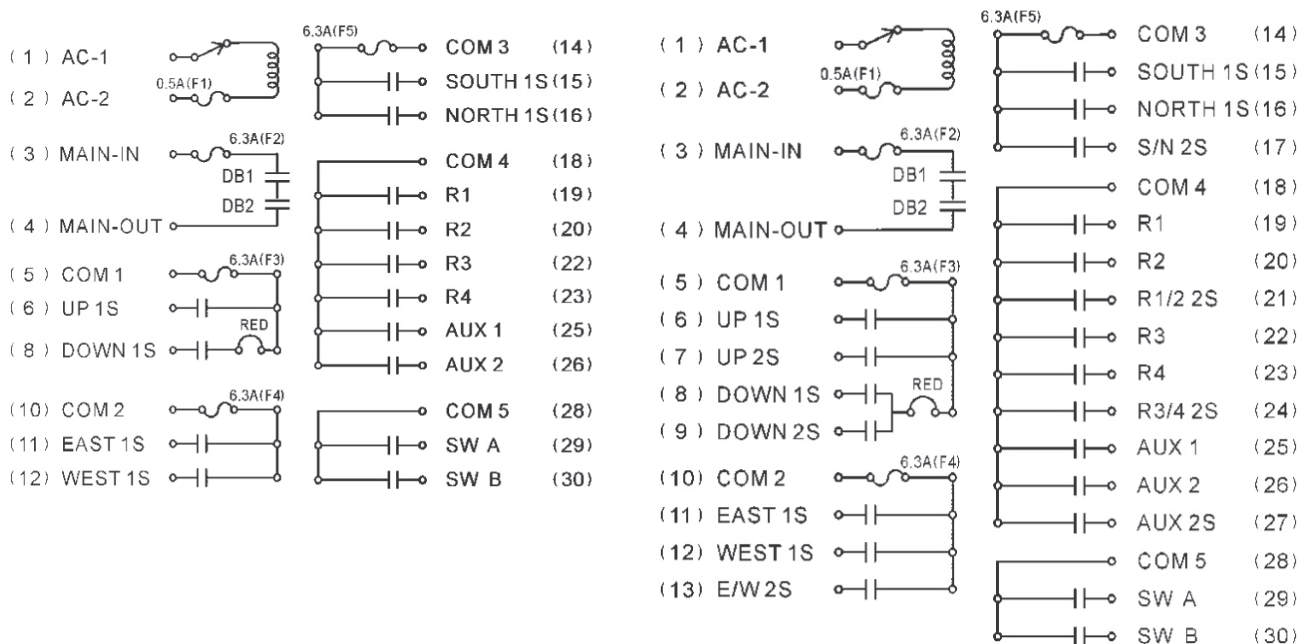

K3 and K4 Series Specification Data Sheet

Request Date	_____	Sales Person	_____
Company	_____	Name	_____
	_____	Title	_____
	_____	Phone	_____
	_____	Fax	_____
Company Type	_____	E-mail	_____

Model Needed K3 (Single Speed) K4 (Dual Speed)

Write the desired button function on the lines next to the buttons:

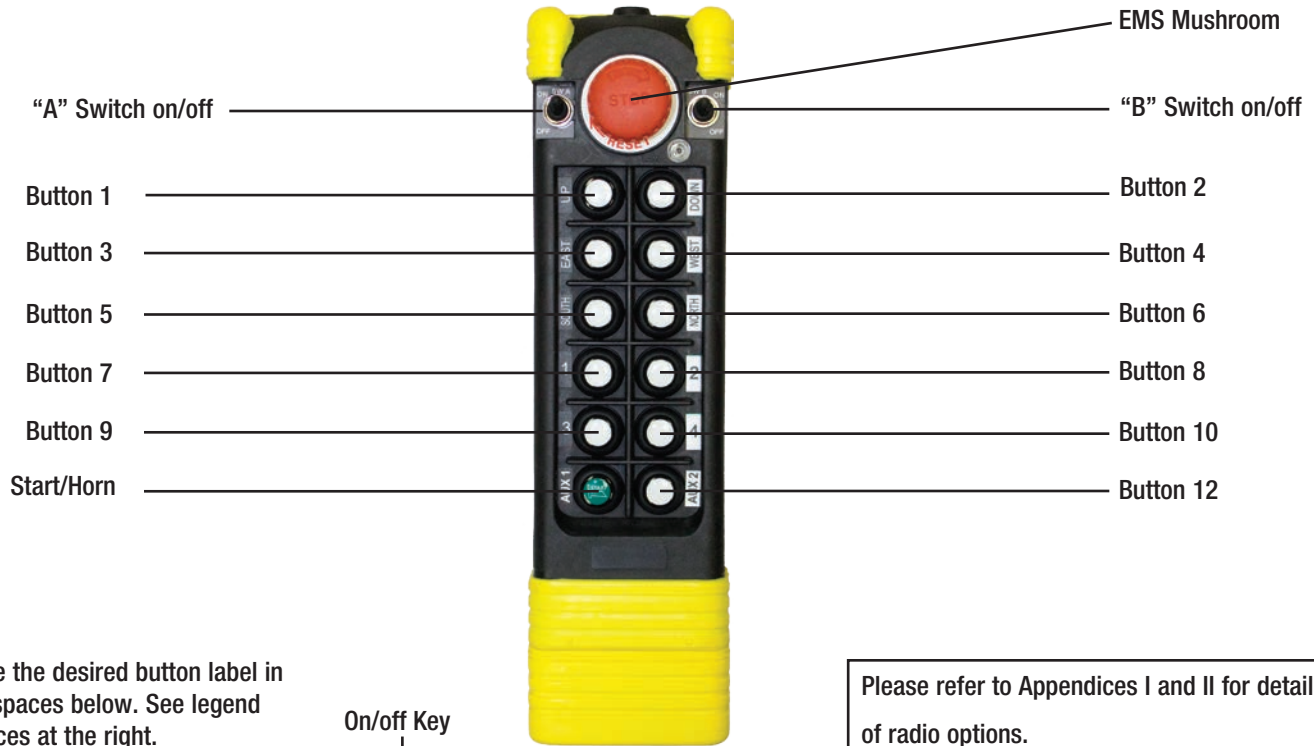

Write the desired button label in the spaces below. See legend choices at the right.

On/off Key

Button 1 _____

Button 2 _____

Button 3 _____

Button 4 _____

Button 5 _____

Button 6 _____

Button 7 _____

Button 8 _____

Button 9 _____

Button 10 _____

Start/Horn _____

Button 12 _____



Part No. 52767

Please refer to Appendices I and II for details of radio options.

Special instructions and options:

Radio Remote Control Accessories

Miscellaneous Accessories

Item	For Radio Series	Description	Part No.
NiCad Battery Charger	K	Microprocessor controlled, keeps up to 4 batteries at full charge without overcharging. Requires 110/1/60 supply.	700DIROP4-4
Copy Memory Module	K	Allows uploading of current transmitter and receiver settings for later download to duplicate transmitter or receiver.	52763
Copy Memory Module	L10, L12, L40, Protean	Allows uploading of current transmitter and receiver settings for later download to duplicate transmitter or receiver.	700PROC
AA NiCad Battery	K and L40	1.2V, rechargeable, 700mAH	700DIROP8
AA Alkaline Battery (All Series)	All	1.5V., 1500mAH	700DIROP10
Radio Pendant Transfer Switch	All	2-pole, radio-off pendant switch with legend	700DIROP22
Protective Cover / Rubber	K 1/2, L10, Proean HT	Transmitter rubber cover guard	52745
Protective Cover / Plastic	K 1/2, L10, Protean HT	Transmitter plastic cover guard	52744
Protective Cover / Plastic	K 3/4	Transmitter plastic cover guard	52746
Protective Cover / Rubber	Protean	Transmitter rubber cover guard	701P0009

Dipole Antenna

The Dipole Antenna is ideal for installations that require an external antenna to improve reception or where the receiver is mounted in an electrical control box. The Dipole Antenna includes six feet of coaxial cable. Extension cables are available below.



- For indoor or outdoor use
- SWR < 1.2 (434 MHz)
- Antenna gain = 0dB
- Suitable for frequencies from 414 MHz to 483 MHz
- Signal loss: 3dB per each 33 feet (10 m)
- Antenna is mounted with 1/4 20 x 1 1/2" long mounting bolts
- Antenna dimensions: 12.62H (321mm) pole, with two horizontal antenna at the top measuring 13W (330mm)

Cable Lgth ft (m)	Antenna Part No.
6 (1.828)	700DIROP9

Safety and Reliability



Safety

Our wireless technology incorporates the latest advancements in Radio Frequency (RF) and microprocessor design. Such features as output relay monitoring, dual micro-controllers, and redundant Emergency Mushroom Switch (EMS) contacts all insure the safe wireless operation of your equipment. Most of all, wireless technology removes the operator from harms way. The operator can choose the safest and most convenient operating position, thus greatly reducing the risk of injury.



Operational Reliability

Extensive use of advanced manufacturing technology and advanced digital technology reduces the part count and simplifies design. Single board transmitter and receiver designs reduce interconnections and enhance reliability. All circuitry is shock-proof mounted within a rigid glass filled nylon enclosure for long service life.

Safety and Reliability

Durability

Conductix-Wampfler Protean, L Series, and K Series radios are well suited to manufacturing, material handling, and automation applications. All transmitter units are sealed from the environment in a fully gasketed NEMA 4 (IP56) enclosure.



Support

All products are backed by Conductix-Wampfler's years of experience in the material handling business. All items are stocked and shipped from one of our two U.S. factories. Our team of qualified engineers are ready to provide you prompt professional service whenever and wherever you need it.



Appendix I K Series Push Button Function Settings - 1

The information below is taken from the “K Series Advanced User Manual”. It is presented here to provide some useful term definitions and is presented here for information only. This material is not designed to replace or supersede the information in the manual itself.

Normal Momentary (Default)

When the push button is pressed and held down, the relative relay is “on”. When the push button is released, the relative relay is “off” .

Toggle (Maintained)

To press the push button and release once for “on” and re-press and release for “off”, back and forth, is called a “Toggle”. For instant, the Toggle function is usually used as a switch to control lighting.

ON / OFF

Two relative push buttons are set to respectively control the same relay. If a push button set as “on” is pressed then released, the relay remains in conduction. To de-energize the relay, press the push button set as “off”. This is like turning the switch of a water pump ON or OFF by the respectively push buttons.

Interlock

If the motions cannot operate simultaneously, they are “Interlocked”, e.g. UP and DOWN push buttons are typically “Interlocked”.

Non-Interlock

If the motions are allowed to operate simultaneously, “non-interlock” as been selected.

Interlock Delay Time

The interval delay time is the time before next motion is valid. For example, to prevent brake damage, there is an interval time before next motion e.g.: “UP - (Interval Delay) - Down”.

Magnetic ON / OFF

Two relative push buttons are set to respectively control the same relay. If a push button set as “Magnetic ON” is pressed then released, the relay remains in conduction. But, when an operator would like to terminate this function, the push button (set as “Magnetic On”) has to be pressed again and held before pressing the push button “Magnetic OFF”. This function is mainly used on electromagnetic device.

Inching

Once the push button is pressed, the relative relay will be activated within some certain period of time to operate a short but precise movement.

Inching 1: Press and release the “START” button first, then press the motion push button (Inching function was active). To terminate the Inching function, press the “START” button again.

Inching 2: Press and hold “START” button then press motion push button to perform the inching motion.

Inching Time

Inching time is used in the situation above to control the time a relative relay activates to accomplish a precise movement only within a short-period time.

Acceleration Delay

This function sets the time interval before the acceleration relay is activated (i.e.: a conduction-delayed time before the acceleration relay). It adds duration between two events to prevent cranes from immediately running to the highest speed and causing damage to the motors.

Dual Motor (Make Before Break Four-Wire Control)

For the 2-step button models, only one relay is active at a time. In other words, press UP 1st step button, the “UP1S” relay turns on. Press deep to the 2nd step and the “UP2S” relay turns on, while the “UP1S” relay turns off. There are 2 modes for Dual Motor as below.

Dual Motors (1): When push button is released from 2nd step to neutral position. The 1st step relay will turns on for very short time till the push button is totally released.

Dual Motors (2): The 1st step relay is not active (or is bypassed) when push button is released from 2nd step to the neutral position.

Synthesis

In synthesis mode, the button functions as normal button. But when two relative buttons pressed simultaneously, it works as “toggle” function.

Note: Synthesis only available on 2-step button models.

Power On Mode

(1) Start Button: The receiver will “Power-On” as the key is turned from “off” to “on” position. Then press the “START” button

(2) Power On with Password: This function is used to set a restriction for unauthorized operators. A password sequence will be required before turning the transmitter on. Select 4 push buttons as password from UP/DOWN, EAST/WEST, and NORTH/SOUTH. For example, press the push buttons in accordance with the sequential number (4 digits), for example: Up - Up - Down - Up.

Appendix I K Series Push Button Function Settings - 2

Transmission Mode

- (1) Continuous Transmitting Mode: Transmitter will continuously transmit signal during “Power-On”.
- (2) Non-continuous Transmitting Mode: After “Power-On”, the transmitter will transmit signal only as the push button is pressed. This mode can save the power of transmitter.

TX (Transmitter) Auto-Off Time

Transmitter will turn off the power automatically after a certain time has passed without any operations being performed.

Note: TX Auto-Off Time function is only available when “continuous transmitting mode” has being selected.

TX Auto-Off EMS (Emergency Mushroom Stop)

Sets the transmitter to transmit the EMS signal to switch off the receiver before transmitter turns off automatically.

Note: TX Auto-Off EMS function is only available when “continuous transmitting mode” has being selected.

LED Interval Time

LED Interval (Inter.) Time means TX power indicator will lighten and vanish between an interval time. For instance, the time showing on the program indicates the duration of interval time.

Passive EMS

The function of “Passive EMS” is used to set the duration of “Interference Neglected Time”. It is able to be set dependant upon environment conditions, which means the duration of practical interference time is less than the duration of “Interference Neglected Time”, in which case the remote controller will continuous perform its function to make cranes keep moving.

Passive Act

The function of “Passive Act” is used to set the reaction of receiver when the duration of interference is more than “Interference Neglected Time”.

Relay Off

Means the Main Relay is still on, but the other relays with the function of “Normal” are all de-energized. It not necessary to recommence the procedure of “Power-On” again to continuously operate.

Power-Off

Means the Main Relay and all of the other relays with the function of Normal” and “Control by EMS” are going to de-energize and it is essential to recommence the procedures of “Power-On” again to continuously operate.

RX (Receiver) Auto-Off

The Receiver Main Relay will power off and de-energize automatically without receiving any signal within a period of time from Transmitter. Normally, when “non-continuous transmitting” mode has been selected and RX Auto-Off will be active in case operators forget to press EMS after completing the task.

Start-Up / Shut-off Alarm

Alarm sounds for two seconds when receiver turns on and off. Select enable to active this function or disable to cancel.

TX Emission PWR (Power)

TX Emission PWR offers eight different power level settings, which will provide operating ranges between the minimum or 65 feet (20m) and the maximum 500 Meters and minimum of 20 meters. Note: The actual operating range will depend on the actual circumstances during operation.

Relay Jammed Detect

If the relay is detected as “jammed”, the main relay will de-energize for safety.

Note: Relay Jammed Detect is only available for UP/DOWN, EAST/WEST, SOUTH/ NORTH relays in “Normal” function.

Remote Pairing

If the Remote Pairing setting is set at “enable”, the remote pairing function is effective. For standard operating procedures, please refer Appendix II, “Special Function Setting”. To cancel remote pairing function, select “disable”.

Manual Channel Scan

If “Manual CH Scan” is selected as “enable”, manual channel scan is effective. For standard operating procedures, please refer Appendix II, “Special Function Setting”. To cancel Manual CH Scan function, select “disable”.

Channel

Operators can set frequency among CH1-CH70. There are 70 channels available.

Appendix II K Series Special Function Setting

The information below is taken from the “K Series Advanced User Manual”. It is presented here to provide some useful term definitions and is presented here for “information only”. This material is not designed to replace or supercede the information in the manual itself.

Manual Channel Scan (if enabled)

Precaution: In order to maximize signal strength without having any disturbance please make sure transmitter and receiver close to each other as possible when operating this function.

Working principles of Manual CH Scan: First, the transmitter sends a command signal, requesting the receiver to automatically search for the best operating frequency at the moment. When this command has been received and confirmed, receiver will start searching for a new suitable frequency and it will be updated and restored as the new operating frequency into both the Transmitter and Receiver.

Standard procedure of operating Manual CH Scan

1. Press “EMS” mushroom, then turn rotary key to “OFF” position.
2. Press and hold the “START” push button.
3. While still pressing the “START” button, turn the rotary key from the “OFF” to “ON” position.
4. Release “START” push button and LED indicator flashes Green, Yellow, and Red sequentially.
5. Press “ UP “ Push button. LED indicator will flash Yellow.
6. When the LED indicator turns from Yellow to Green and vanishes, the new frequency has been updated successfully.
7. When the new frequency has been updated, turn the rotary key from “ON” to “OFF” position. “Manual CH Scan” is completed.

Note: If LED indicator turns from Yellow to Red and vanishes, the process failed. If this happens, repeat the processes starting with Step 1.

Remote Pairing (if enabled)

Remote Pairing works as follows: Initially, the transmitter will search the receiver or receivers that are requesting to be matched. Next, as the receiver has been found and confirmed by operator, the receiver will upload its function settings: e.g. ID-code and frequency into transmitter in order to pair a matched transmitter and receiver. This performance eliminates the trouble of having to physically access the receiver.

Standard Procedure for Operating Remote Pairing

1. Press EMS” mushroom and turn rotary key to “OFF” position.
2. Press and hold “START” push button,
3. While still pressing the “START” button, turn the rotary key from “OFF” to “ON” position.
4. Release “START” push button and LED indicator flashes Green, Yellow, and Red sequentially.
5. Press “DOWN” push button and the LED indicator will flash Green and Red, which indicates that the Transmitter is doing the task of searching for the matched Receiver.
6. When matched receiver is found, the LED indicator will turn to Green.
7. To double-check that the receiver which has been found is right one or not, the operator can press the “START” push button to verify it by the receiver power indicator and the beeping from the receiver.
8. If the transmitter finds a receiver which is not correct one, press the “ DOWN” push button, repeat the procedure until correct matched receiver is found.
9. When the transmitter finds a confirmed and matched receiver, press the “UP” push button and the LED indicator of the ransmitter will flash yellow which means data is going to be downloaded into the transmitter.
10. When the LED indicator of the transmitter turns from yellow to green, press the “ UP “ push button to confirm it. Then the LED indicator of transmitter will flash green four times showing that all data has been transferred completely.
11. Turn rotary key from “ON” to “OFF” position.
12. “Remote Pairing” is completed.

Note: If there is no receiver found, the LED indicator of the transmitter will flash red four times, which means the “Remote Pairing” processes have been aborted.

Appendix III Terms, Conditions, and Warranty

The technical data and images which appear in this catalog are for informational purposes only. NO WARRANTIES, EXPRESSED OR IMPLIED, INCLUDING WARRANTIES OF MERCHANTABILITY OR FITNESS FOR A PARTICULAR PURPOSE, ARE CREATED BY THE DESCRIPTIONS AND DEPICTIONS OF THE PRODUCTS SHOWN IN THIS CATALOG. Conductix-Wampfler (“seller”) makes no warranty and assumes no liability as to the function of equipment or the operation of systems built according to customer design or of the ability of any of its products to interface, operate or function with any portions of customer systems not provided by Conductix-Wampfler.

Seller agrees to repair or exchange the goods sold hereunder necessitated by reason of defective workmanship, and material discovered and reported to Seller within one year after shipment of such goods to Buyer. Except where the nature of the defect is such that it is appropriate in Seller’s judgement to effect repairs on site, the seller’s obligation hereunder to remedy defects shall be limited to repairing or replacing (at Seller’s option), FOB point of original shipment by Seller, any part returned to Seller at the risk and cost of Buyer. Defective parts replaced by Seller shall become the property of Seller.

Seller shall only be obligated to make such repair or replacement of the goods which have been used by Buyer in service recommended by Seller and altered only as authorized by Seller. Seller is not responsible for defects which arise from improper installation, neglect, or improper use or from normal wear and tear.

Additionally, Seller’s obligation shall be limited by the manufacturer’s warranty (and shall not be further warranted by Seller) for all parts procured from others according to published data, specifications, or performance information not designed by or for Seller.

Seller further agrees to replace, or at Seller’s option to provide a refund of the sales price of any goods that did not conform to applicable specifications or which differ from that agreed to be supplied which non-conformity is discovered and forthwith reported to Seller within thirty (30) days after shipment to Buyer. Seller’s obligation to replace or refund the purchase price for non-conforming goods shall arise once Buyer returns such good FOB point of original shipment by Seller at the risk and cost of Buyer. Goods replaced by Seller shall be come property of Seller.

There is no guarantee or warranty as to anything made or sold by Seller, or any service performed, except as to title and freedom from encumbrances, and except as herein expressly stated and particularly without limiting the foregoing. There is no guarantee or warranty, express or implied, of merchantability or of fitness for any particular purpose or against claim of infringement or the like.

Seller makes no warranty (and assumes no liability) as to function of equipment or operation of systems built to Buyer’s design or of the ability of any goods to interface, operate or function with any portions of Buyer’s system not provided by Seller.

Seller’s liability on any claim; whether in contract (including negligence) or otherwise, for any loss or damage arising out of, connected with, or resulting from the manufacture, sale, delivery, resale, repair, replacement or use of any products or, services shall in no case exceed the price paid for the product or services or any part thereof which give rise to the claim. In no event shall Seller be liable for consequential, special, incidental or other damages, nor shall Seller be liable in respect to personal injury or damage to property on the subject matter hereof unless attributable to gross misconduct of Seller, which shall mean an act of omission by Seller demonstrating reckless disregard of the foreseeable consequences thereof.

Seller is not responsible for incorrect choice of models or where products are used in excess of their rated and recommended capacities and design functions or under abnormal conditions. Seller assumes no liability for loss of time, damage or injuries to property or persons resulting from the use of Seller’s products. Buyer shall hold Seller harmless from all liability, claims, suits and expenses in connection with loss or damage resulting from operation of products or utilization of services, respectively, of Seller and shall defend any suit or action which might arise there from Buyer’s name, provided that Seller shall have the right to elect to defend any such suit or action for the account of Buyer. The foregoing shall be the exclusive remedies of the buyer and all persons and entitles claiming through the Buyer.



Push Button Pendants

Conductix-Wampfler has offered ergonomic, high quality Push Button Pendants since the early 1990's.

We offer dozens of standard push button pendant configurations to suit the unique needs of demanding industrial users. These modular push button units are assembled from stocked components for quick delivery and are competitively priced.

The experienced engineering and sales people at Conductix-Wampfler are experts in the application of Push Button Pendants to all kinds of industrial applications.

For details, please ask for **CAT1001** "Push Button Pendants" or download the PDF from our web site.

All Conductix-Wampfler plants in the United States, Germany, France, and Italy are ISO 9001:2000 certified. Our stringent quality systems assure that you will get the right product every time.

Conductix-Wampfler in Omaha, NE started as "Industrial Electric Reels" (IER) and later merged with "Insul-8 Corporation", after relocating the Insul-8 plant to Harlan, IA. In 2006, the company, part of the Delachaux Group since 1975, was renamed "Conductix".

In 2007, with the merger of Conductix and Wampfler, the company is now the world leader in the design and manufacture of high performance energy and data transmission products for industrial applications.



80 Series

Ergonomic; Accommodates from 2 to 12 buttons. Many configurations. High-impact NEMA 4X case with Neoprene-booted buttons. 2 and 3 button Pistol Grip versions available.

UL / cUL Listed



60 Series

Economical; 2 to 4 buttons. Many configurations available. High-impact NEMA 4 case. A 2-button Pistol Grip version available.

UL / cUL Listed



20 Series

For direct control over small single phase motors at 120 or 240 volts. Durable NEMA 4 housing.

UL / cUL Listed



Pre-Wiring Option

All pendants can be ordered pre-wired. Contact the Factory for details!



Other Products from Conductix-Wampfler

Spring Driven Cable Reels from Conductix-Wampfler represent only one product line from the broad spectrum of Conductix-Wampfler components for the transfer of energy, data, gases, and fluids. The solutions we deliver for your applications are based on your specific requirements. In many cases, a combination of several different Conductix-Wampfler products are needed to fill the application. You can count on all of Conductix-Wampfler's business units for hands-on engineering support - coupled with the perfect solution to meet your energy management and control needs.



Motor driven cable reels

Motor driven reels by Conductix-Wampfler are the perfect solution for managing long lengths of heavy cable and hoses in very demanding industrial applications. Monospiral, level wind, and random wind spools.

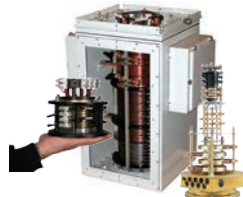

Slip ring assemblies

Whenever powered machinery needs to rotate 360°, field proven slip ring assemblies by Conductix-Wampfler can flawlessly transfer energy and data. Here, everything revolves around flexibility and reliability.



Energy guiding chains

The "Jack of all Trades" when it comes to managing energy and data cables and air and fluid hoses. A wide range of energy guiding chains are available for many industrial applications.



Inductive Power Transfer IPT®

The contact-less system for transferring energy and data. For all tasks that depend on high speeds and absolute resistance to wear.



Conductor bar

Whether they are enclosed conductor rails or expandable single-pole bar systems, Conductix-Wampfler's conductor bar is the proven solution to reliably move people and material.



Cable Festoon systems

It's hard to imagine Conductix-Wampfler cable trolleys not being used in virtually every industrial application. They are reliable and robust and available in an enormous variety of sizes and models.



Push Button Pendants

Our ergonomic pendants are ideally suited for industrial control applications. They are available in a wide range of configurations for overhead cranes and other machinery.



Welded Cap Conductor Rail

Our patented Welded Cap Rail gives you the conductivity and light weight of aluminum plus the wearability of stainless steel.



Workstation equipment

Complete with tool transporters, reels, or an entire air and electric supply system. Workstation equipment provides safety and flexibility for difficult tasks.



Air hoists and balancers

ENDO Air hoists accurately place delicate loads and continuously vary the speed for precise positioning. They run cool in **continuous operations**.



Bumpers

Conductix-Wampfler offers a complete range of bumpers for the auto industry, cranes, and heavy machinery. These include rubber, rubber/metal, and cellular types.



Spring balancers and retractors

ENDO spring balancers by Conductix-Wampfler are rugged, reliable high-precision positioning devices that reduce operator fatigue and assist with accurate tool placement.

www.conductix.us

USA / LATIN AMERICA

10102 F Street
Omaha, NE 68127

Customer Support

Phone +1-800-521-4888

Fax +1-800-780-8329

Phone +1-402-339-9300

Fax +1-402-339-9627

info.us@conductix.com

latinamerica@conductix.com

CANADA

175 Blvd JF Kennedy
St. Jerome, QC J7Y 4B5

Customer Support

Phone +1-800-667-2487

Fax +1-800-442-9817

Phone +1-450-565-9900

Fax +1-450-432-6985

info.ca@conductix.com

MÉXICO

Calle Treviño 983-C
Zona Centro
Apodaca, NL México 66600

Customer Support

Phone (+52 81) 1090 9519

(+52 81) 1090 9025

(+52 81) 1090 9013

Fax (+52 81) 1090 9014

info.mx@conductix.com

BRAZIL

Rua Luiz Pionti, LT 05, QD.
L - Vila Progresso
Itu, São Paulo, Brasil
CEP: 13.313-534

Customer Support

Phone (+55 11) 4813 7330

Fax (+55 11) 4813 7330

info.br@conductix.com

Contact us for our Global Sales Offices

